



### Features

- Laminar flow nozzle supplied standard to reduce the spread of Legionella.
- Smooth round, clean design to make cleaning easier and help reduce the dirt and bacterial growth on the top.
- Low lying handles to facilitate the ease of use and improve hand hygiene practices.
- Bright chrome plate finish for easy cleaning and added durability.

### To Specify

The Clinilever® range is specifically designed for hospital and medical preparation areas. The innovative design helps to combat the risk of hospital acquired infections and minimise bacteria risk while providing a time and cost effective solution to maintenance.

#### Code:

**TCBFJ80C** - Clinilever® CP-BS Hospital Basin Set Fixed, 80mm Lever Handles, Jumper Valve



A family owned Australian business



## Performance Standards & Approvals

- AS/NZS 3718 – WaterMark
- WELS 4 Star Rating



## Typical Dimensions

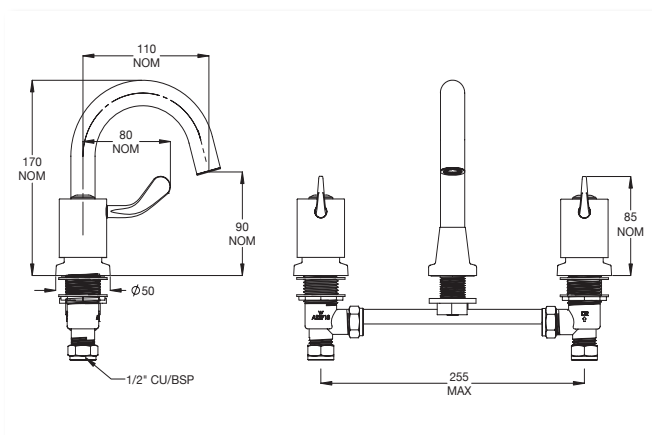

## Technical Information

- Inlet: 1/2" CU/BSP - Female
- Outlet: Laminar Flow
- Headwork: Jumper Valve
- Working Pressure Range (kPa): 50 Min - 500 Max
- Working Temperature Range (°C): 5 Min - 65 Max
- Nominal Flow Rate (LPM): 6.3
- Construction: Brass
- Finish: Chrome

## Maintenance & Cleaning

Galvin Engineering products should be cleaned with a soft damp cloth using only mild liquid detergent or soap and water. Do not use cleaning agents containing a corrosive acid, scouring agent or solvents. Do not use cream cleaners, as they are abrasive. Use of unsuitable cleaning agents may damage the surface. Any damage caused in this way will not be covered by warranty.

Regular maintenance should be carried out in accordance with the installation and troubleshooting guides provided with the product, relevant Australian Standards, local authorities and state codes.

As part of maintaining a safe and reliable plumbing system, we recommend tapware and valves are operated on at least a daily basis.

## Warranty

Galvin Engineering products are covered under our Manufacturer's Warranty at [www.galvinengineering.com.au](http://www.galvinengineering.com.au). Galvin Engineering products must be installed in accordance with the installation instructions and in accordance with AS3500 and the PCA, relevant Australian Standards and local authorities applicable to product being installed. Water and electrical supply conditions must also comply to the applicable national and/or state standards, failing to comply with these provisions may void the product warranty and affect performance of the product.

Whilst all reasonable care has been taken in compiling the information in this document, the designs, dimensions and products shown are indicative only and should not be relied upon without our prior approval. Due to our policy of continuous development, we reserve the right to alter any details of specifications or products without notice. All information, drawings, technical specifications and product designs remains the property of Galvin Engineering Pty Ltd.

Within Australia: **1300 514 074** Outside Australia: P: +61 (0)8 9338 2344

F: +61 (0)8 9338 2340

[sales@galvinengineering.com.au](mailto:sales@galvinengineering.com.au)

[www.galvinengineering.com.au](http://www.galvinengineering.com.au)

ABN: 78 008 719 382



PERTH | SYDNEY | MELBOURNE | BRISBANE | ADELAIDE | UNITED STATES OF AMERICA | UNITED KINGDOM | NEW ZEALAND